



## Industrial Management & Data Systems

Improving the effectiveness of warehousing operations: a case study

A. Gunasekaran, H.B. Marri, F. Menci,

### Article information:

To cite this document:

A. Gunasekaran, H.B. Marri, F. Menci, (1999) "Improving the effectiveness of warehousing operations: a case study", Industrial Management & Data Systems, Vol. 99 Issue: 8, pp.328-339, <https://doi.org/10.1108/02635579910291975>

Permanent link to this document:

<https://doi.org/10.1108/02635579910291975>

Downloaded on: 19 December 2018, At: 18:23 (PT)

References: this document contains references to 19 other documents.

To copy this document: [permissions@emeraldinsight.com](mailto:permissions@emeraldinsight.com)

The fulltext of this document has been downloaded 9398 times since 2006\*

### Users who downloaded this article also downloaded:

(2002), "Linking warehouse complexity to warehouse planning and control structure: An exploratory study of the use of warehouse management information systems", International Journal of Physical Distribution & Logistics Management, Vol. 32 Iss 5 pp. 381-395 <<https://doi.org/10.1108/09600030210434161>><https://doi.org/10.1108/09600030210434161></a>

(2002), "A framework for the design of warehouse layout", Facilities, Vol. 20 Iss 13/14 pp. 432-440 <<https://doi.org/10.1108/02632770210454377>><https://doi.org/10.1108/02632770210454377></a>

Access to this document was granted through an Emerald subscription provided by emerald-srm:198213 []

### For Authors

If you would like to write for this, or any other Emerald publication, then please use our Emerald for Authors service information about how to choose which publication to write for and submission guidelines are available for all. Please visit [www.emeraldinsight.com/authors](http://www.emeraldinsight.com/authors) for more information.

### About Emerald [www.emeraldinsight.com](http://www.emeraldinsight.com)

Emerald is a global publisher linking research and practice to the benefit of society. The company manages a portfolio of more than 290 journals and over 2,350 books and book series volumes, as well as providing an extensive range of online products and additional customer resources and services.

Emerald is both COUNTER 4 and TRANSFER compliant. The organization is a partner of the Committee on Publication Ethics (COPE) and also works with Portico and the LOCKSS initiative for digital archive preservation.

\*Related content and download information correct at time of download.

---

# Improving the effectiveness of warehousing operations: a case study

A. Gunasekaran  
University of Massachusetts, North Dartmouth, Massachusetts, USA  
H.B. Marri  
Brunel University, Uxbridge, Middlesex, UK  
F. Menci  
Brunel University, Uxbridge, Middlesex, UK

## Keywords

Warehousing, Case studies,  
Through-put time, Just-in-time,  
TQM

## Abstract

The warehouse is the interface area for production lines, market, customers and suppliers, and the business environment in general. Goods inwards (GI), constituting part of the warehouse activities, is the department responsible for booking-in the incoming parts from external suppliers. After the production process is improved, the resources in the warehouse are balanced to link the internal/external transfer of physical items. With a broader view of the GI activities, and a look into its future, the actual problems may become clear, understandable, and hence easy to solve. The aim of this paper is to study the problem areas in GI and provide solutions to increase the performance of warehousing operations. First, a conceptual framework has been developed to improve the effectiveness of warehousing operations. Second, a case study has been conducted with the help of the model to minimize the through-put time in warehousing operations. Finally, a summary of findings and recommendations are presented.

---

## Industrial Management &

---

## Introduction

The general warehousing concept includes the storage and retrieval operations, the organizational aspects, the mechanisation equipment for materials handling, media for material storage, and the building itself which is necessary to protect the goods' environments. The task of distribution consists of moving goods from the production line to the customer in an acceptable time and doing it economically. However, there are an infinite number of solutions. Optimum or near-optimum solutions are difficult to find and often involve more than errand-running ingredients for the shortest path as well as the removal of unnecessary waiting time. Inventory control, production control and warehouse management are the underlying methodologies that affect the industrial success of distribution organizations. Both the physical processes of material handling and stocking, as well as the underlying methodologies, are commonly denoted by the word "warehousing".

Warehousing activities concern the physical storage and retrieval of materials, and also the processing of information needed about the goods stored. For example, lot (or the parcel) has an origin, its supplier, an identification, its designation, a dimension (usually the quantity), a destination and a customer. Basically, warehousing methodology is information-oriented and requires the use of efficient media to store and handle data about the movement of goods. It is important to have good control over the inventory. Management should ensure that, for each item:

- the correct stock level is available;
- no unnecessary money is tied-up in inventory;
- the warehouse capacity is both economical and efficient; and
- the goods are properly kept.

To achieve this, a focus on the correct evaluation, identification, classification and

---

The authors are most grateful to the then Editor (Sue de Verteuil) for her extremely constructive and helpful comments on the earlier version of the manuscript that helped to improve the presentation of the paper considerably. Also, the authors would like to thank the employees of Lucas Heavy Electrical for their support in this project.

quantification, retrieval, and security of goods, would provide a clear and accurate view (Chorafas, 1974).

Over the past 20 years, the automotive industry has been sinking deeper and deeper into recession. Owing to massive technological developments, a worker of the 1990s can produce as much as ten workers could in the 1960s. To remain at the forefront of progress, competition is fierce, and productivity and efficiency are nowadays

the major focus of all development programmes in modern industry. For instance, it was proven that internal combustion engines are highly pollutant, so manufacturers had to act on this research, and are continuously striving to reduce the environmental risk of their present products.

Environmental concern is not a fashion, or a passing fad; it has been established as a serious world issue in our society. Therefore, it is logical to expect that the motor industry will reduce even more in size. To remain competitive in the global market, companies endeavour to maximize both their productivity and their quality. Warehouse performance measures should be based on organizational strategies, objectives and competitive demands. Effective

performance measurement systems go beyond reporting history to improving future operations.

The measurement system must be balanced between internal and external perspectives (Tompkins, 1996).

A number of researchers and practitioners have studied warehousing operations from different perspectives, such as receiving, storing, picking, packing and shipping operations. However, there have not been many articles that address the improvement of warehousing operations in real-life situations. Also, a conceptual framework is lacking for improving the warehousing operations taking into account the concept of just-in-time (JIT) and total quality management (TQM) together with information technology (IT). Realizing the importance of

warehousing operations in improving customer service levels, an attempt has been made to study this subject with the help of a case study.

**Data Systems**  
99/8 [1999] 328-339

© MCB University Press  
[ISSN 0263-5577]

The current issue and full text archive of this journal is available at  
<https://www.emerald-library.com>



## Warehousing operations

Today's warehouses may function autonomously, but they must also learn to think universally. This can lead to the development of advanced systems built on the idea of distribution at an enterprise level, connecting multiple sites and supply chains together for a network-centric view (Dilger, 1998). Storage is the core activity of warehousing and it identifies the location where the goods are deposited and held until they are demanded for usage. Since items are of many different shapes and sizes, there are also different usage rates of the storage space, which poses different problems. For example, first-in first-out (FIFO) storage, or a stock - or even a dedicated - container are useful storage mechanisms. They must be designed to fit each item, or category of items.

Built-in flexibility can be an advantage for continuous improvement of the inventory control. Online analytical processing (OLAP) and data analyses are the decision support technologies used in warehousing operations. The main objective of these technologies is to enable enterprises to gain competitive advantage by exploiting the ever-growing amount of data that are collected and stored in corporate databases and files for better and faster decision making (Chaudhuri and Dayal, 1997).

Typically, warehousing comprises six major throughput activities (see Figure 1):

- 1 receiving;
- 2 transfer;
- 3 handling;
- 4 storage;
- 5 packing; and
- 6 expediting.

Once the materials are transferred to the storage area, or when they are transferred to the expediting area, handling takes the parts into or from their location. To minimize the time expended in retrieving orders, it is suggested that items that have the highest turnover are located nearest to the shipping area. Slow-moving items would be kept at the other end of the store. While expediting materials, the preparation of all information documents is connected. Work carriers are unloaded, items are sent for packing. Before

shipping, final checks on the shipping invoice and for possible damage are made. Packing is an important element of the despatch function. Although it is not directly connected with the warehouse operation, it usually finds its place within the same building. The warehouse must assume the responsibilities of linking containerization which would improve the cost-effectiveness of transportation, facilitate the mechanisation of the warehouse, reduce the amount of packaging material used and save on an expensive recycling scheme. Ang and Andren (1995) have pointed out in their paper that YoungWorld, a rapidly growing retailer of children's apparel and furniture, eliminated their warehouse bottlenecks by replacing the redundant, paper-intensive manual operations with an automated warehouse system. With automation and barcoding technology, YoungWorld reduced labour by half and saved 25 per cent on warehouse overheads with a payback time of slightly over two years.

Improvement of warehouse operations can be realized using software and automatic data collection. In particular, barcodes in conjunction with software can be used to provide a better view of warehouse operations by collecting accurate data on:

- the space utilization;
- return on investment;
- material handling equipment use;
- labour cost;
- order picking; and
- customer service (Nixon, 1994; Trunk, 1994b).

Software is an important control and scheduling tool suited for the enhancement of warehouse operations. Although software may not help much when the material handling equipment is insufficient for the task, considering it seriously is an important step to better handling of goods, keeping track of the inventory and serving customers (Trunk, 1994a). Order picking in conventional warehouse environments involves determining a sequence in which to visit the unique locations where each part of the order is stored, and thus is often modeled as a travelling salesperson problem. With the computer tracking of inventories, parts may

Figure 1  
Activities in warehousing operations

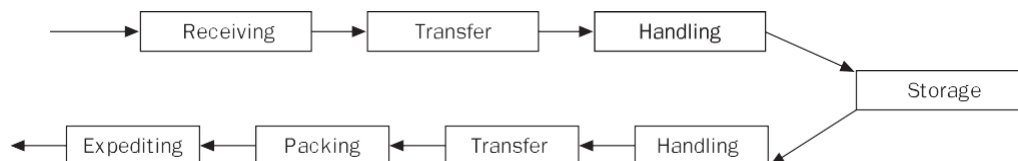

A. Gunasekaran, H.B. Marri and F. Menci  
*Improving the effectiveness of warehousing operations: a case study*

Industrial Management & Data Systems  
 99/8 [1999] 328-339

now be stored in multiple locations, simplifying replenishment of inventory and eliminating the need to reserve space for each item (Daniels *et al.*, 1998).

Warehouse layouts are the perfect examples of fundamentals often neglected. Most organizations simply treat the warehouse as a place where product is stored until it needs to be shipped to the customer. This often results in the shutdown of warehouses. Suskind (1995) examined a company whose only warehouse facility was nearly shut down. He emphasized the approach used by the company to meet its peak inventory storage and shipping requirements. A properly installed warehouse management system (WMS) can revolutionize the way a company does business. Any changes in WMS should be properly communicated and co-ordinated throughout the organization in advance.

### A conceptual model to improve the effectiveness of warehousing operations

In order to present a framework for improving the effectiveness of warehousing operations, a conceptual model has been developed as shown in Figure 2. The issues of improving warehousing operations are discussed under two perspectives:

- 1 JIT; and
- 2 TQM.

The JIT application in warehousing operations is concerned with demand pull, minimal economic quantity, reduce work-in-progress (WIP), supplier reliability,

preventive maintenance and eliminate buffers. The issues related to TQM are a long-term commitment, war on waste, continuous improvement, total quality control (TQC), continuous training and ergonomics. JIT helps in scheduling the operations, reduces lead time, inventory, through-put time and improves on-time delivery of the goods to different destinations. TQM helps to improve the effectiveness and quality control in warehousing operations. Further details of improving warehousing operations are discussed later.

### JIT application in warehousing operations

JIT is a philosophy which aims to bring certainty and smoothness to the flow of material through the supply chain, while reducing the WIP, enabling the lowering of stock, and thus reducing the lead time. For many buying companies, JIT forces the supplier to carry stock in order to ensure timely delivery. In fact, this could be described as a transfer of inventory to another location within the supply chain. The proper approach implies more co-operation to ensure success. JIT is the application of an externally-oriented approach to scheduling, but its implementation also has an impact on inventory management and other areas (Wild, 1995). JIT emphasizes improving the manufacturing efficiency as an operating system to solve productivity problems. JIT aims to reduce the inventory and through-put time, thus decreasing the number of parts waiting. The new system has to be ergonomic, or user-friendly", and approved by all the staff. This operational analysis emphasizes the removal of unnecessary

Figure 2

A conceptual model for improving the efficiency of warehousing operations

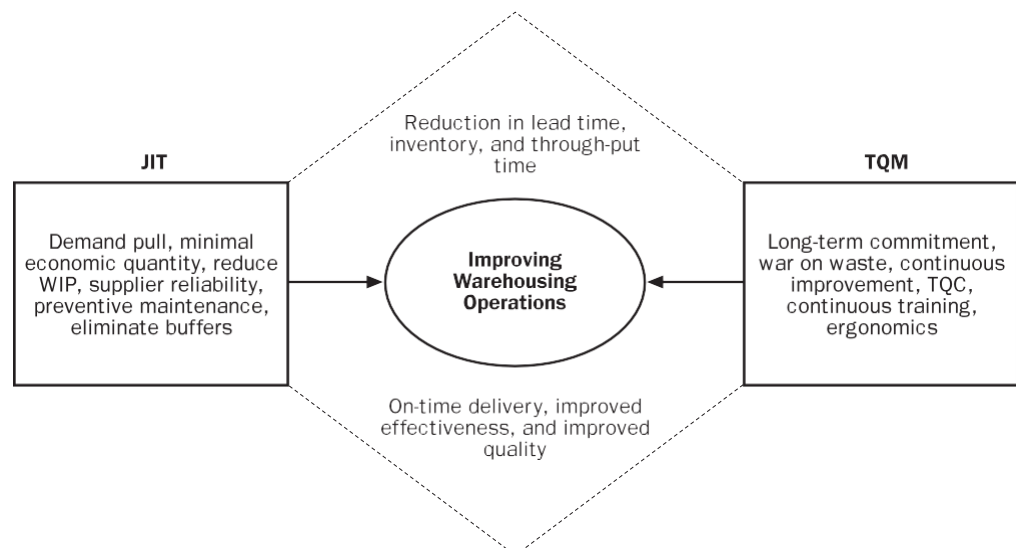

---

A. Gunasekaran, H.B. Marri  
and F. Menci  
*Improving the effectiveness of  
warehousing operations: a  
case study*

---

Industrial Management &  
Data Systems  
99/8 [1999] 328-339

---

workload and aims to bring the information flow in line with the physical flow in order to optimize the overall process time. Cormier and Kersey (1995) present a case study to outline some analysis and design principles for a central distribution facility in warehousing operations to support a JIT operating philosophy. They have presented various facets of the study, such as the determinations of storage and through-put requirements, a conceptual warehouse layout and an economic analysis.

JIT is a demand pull system. Manufacturing planning begins with the final stage, last assembly line (or process) and works backwards, through every manufacturing process, and also to the vendors and subcontractors supplying materials and components. JIT and purchasing work effectively if all parts arrive at the right time, in the right place and in the right quantity and, most importantly, if the parts that arrive are usable (Lyson, 1996). The JIT approach contrasts markedly with the warehousing operating systems depending on substantial inventory; it brings exactly what a customer wants, where and when he decides. Therefore, the queuing time of batches is minimal, WIP is low, throughput time and space requirement in the warehouse are reduced and the flows become virtually continuous. There is also an absence of buffers and safety measures, which normally slow down the process.

Efficient warehousing management can bring about valuable developments and philosophies. For example, JIT can further contribute to the improvement in performance of production activities. In particular, it affects the supply chain as, if functioning as intended, it can eliminate factors considered superfluous or excessive, such as non-value-adding activities. It may also enable the lowering of WIP, therefore reducing lead times. Ideally, JIT aims to ensure consistently punctual deliveries of high quality goods, at optimal costs. The industries that are currently having the most success in terms of realizing these goals are those striving to meet international competition. To beat high holding costs, they cut purchase and production lot sizes and dodge buffer stocks.

JIT operating systems in the warehouse must wait for the customer to decide where and when to deliver what. A customer triggers activities throughout the operating system. The order flows back, triggering each stage of the overall process at the proper date. The rapid movement between processes is an essential prerequisite. The time-based dimensions of a product are becoming an

increasingly important component in assessing strategic advantage, while traditional long lead times and high inventory levels are increasingly less important. However, JIT hinges on the rationalisation of the flow and aims to reduce the intrinsic waste in the process of warehousing operations. Major elements of JIT are embedded in a more comprehensive TQM system. JIT emphasises the importance of improving manufacturing efficiency as an operating system to solve productivity problems, while TQM aims to improve the overall effectiveness of the organization through extensive attention to the social aspect of management (Cali, 1993). Fuller (1995) suggested that the implementation of TQM, GT, JIT, MRP, IT and lean production will benefit warehousing operations.

The material flow follows the information flow. If there is any gap between them, it will lead to congestion and poor customer service level. On behalf of a close communication, the responsiveness can be maximised, eliminating the needs for safety stock. As advised by the department of trade and industry in the UK (1995), the following are implications of JIT in warehousing operations:

- JIT hinges on planning and certainty - need for enhanced sales forecast;
- JIT can only work where there is co-operation and trust - need for strong supplier-customer links;
- JIT will break down without proper communication - need for effective information systems;
- awarding supplier long-term contract which gives them the confidence to invest in meeting their future requirements;
- working towards zero defect through a quality assurance programme; and
- removing non-value-adding activities along the whole supply chain.

### TQM application in warehousing operations

TQM is a management approach to organization centred on quality, based on the participation of all its members, and aiming at long-term success through customer satisfaction and benefits to the members of the organization and to society. Since the introduction of a quality approach in manufacturing, it has left its mark on the landscape of the manufacturing industry (Love *et al.*, 1998). The quality and high performance of a company depend on the criteria listed in the following four sub-sections.

#### *Long-term commitment*

To achieve a long-term commitment, one must know the behaviour of a product and its process for the whole of its life-cycle.



---

A. Gunasekaran, H.B. Marri and F. Menci  
*Improving the effectiveness of warehousing operations: a case study*

Industrial Management & Data Systems  
99/8 [1999] 328-339

---

Factories, machines and materials must be economically sound and environmentally friendly. Plan for the long term rather than the short term. Short-term issues and fire-fighting should remain the task of local management. Locally, if authority is increased where the problems in warehousing operations occur, this will increase the ability to solve minor problems, provided that staff are fully trained. This would also release time to concentrate on problems at a higher level in warehousing operations. The use of Pareto analysis on each quantifiable problem helps to resolve them effectively.

#### **War on waste**

Generation of waste in warehousing operations implies two costs:

- 1 the value added, which is lost; and
- 2 the cost of disposals, which is ever increasing.

Along the supply chain, a strict inspection would prevent the process of transporting waste, as once the item is defective, it can only end up as scrap. To generate scrap is also to order things which will remain unused in a store until they go to dump. One more cost occurs in this case: the space occupied in the warehouse. According to Burton (1981), it is always cheaper to do the job right first time.

#### **TQM**

TQC aims to prevent waste by not producing defective products in the first place. It emphasizes that everything is important for the goal of achieving first-class quality. The relationships between suppliers and buyers, leading ultimately to the customer, must be integrated to prevent poor quality, rather than trying to detect what is not to specification. TQC is the process of setting standards of acceptability for the goods purchased in warehousing operations. A specification is a detailed description of any given item. Once the specification has been drawn up, all goods supplied to the store/warehouse must meet the requirements or be rejected.

#### **Continuous training**

One of the main strengths which people have is their flexibility. They will be as flexible as their knowledge allows. Teamwork allows the sharing of skills and know-how among groups in warehousing operations. Therefore, the knowledge of the team reflects to a large extent the knowledge of each member. It requires that each member perform his/her task to the best of his/her ability, while also being able to help his/her fellow team members in warehousing operations. Often,

specialists are required, and they must have the broadest possible knowledge of warehousing operations.

---

### **A case study: Lucas-Acton, England**

An attempt has been made to study the application of the model in a real-life situation (as shown in Figure 2). This section deals with the Lucas warehousing operating system, principally the goods inwards (GI). It specifically highlights the shortcomings of the system; for example, the time spent walking between the work area and the GI office to process deliveries, and also the massive amount of paper work involved, which is costly and time-consuming. Warehouse activities often require the processing of a vast amount of information, and if there is not an adequate level of structural and operational effectiveness, this data handling may become an insurmountable task. Using the philosophies of JIT, it will be seen that several improvements could be made. For example, JIT would ensure a smooth, reliable material flow, thus eliminating buffers, reducing WIP, stock levels and lead times. JIT aims to bring smoothness and certainty to the material flow. This technique helps to reduce the throughput time of a process and, therefore, the number of parts waiting before processing is reduced. The principles of TQM would make the GI procedures more ergonomic, removing unnecessary workload and optimising the overall process time.

#### **Background of the company**

To study the application of the model in the GI operations system, Lucas Electrical Heavy Duty Products, situated in Acton, UK, was selected. Lucas is a small to medium-sized enterprise (SME) with a workforce of 500 and an annual turnover rate of £30 million. Lucas is a manufacturing company that produces starter motors, alternators and electrical motors for electrical, rotating heavy machines. The products are manufactured to stock. It is a high-volume and low-variety production system. The system, including warehousing, follows a push-type scheduling system. The decision making in Lucas follows the top-down approach. Acton Gate four is the main door through which any material goes into and out from the Lucas plant. The transfer function moves the goods from reception to storage and from tier retrieval to delivery at a point where the expediting process starts. Activities such as loading, positioning and unloading are assisted by transfer devices. These transfer



---

A. Gunasekaran, H.B. Marri  
and F. Menci  
*Improving the effectiveness of  
warehousing operations: a  
case study*

---

Industrial Management &  
Data Systems  
99/8 [1999] 328-339

---

devices can be very costly and often represent a large investment. Therefore, solutions must be cost-effective and not haphazard (e.g. the forklift).

Over the past ten years, Lucas Heavy Duty Products has gone through dramatic changes which have significantly affected the size and the structure of the organization. A vertical, functionally integrated structure was turned into a vertically disintegrated process-oriented organisation. The UK-based market expanded to an international supply chain, where suppliers and customers can be based in Europe, Turkey or India. Furthermore, only the key activities were kept in-house, while external suppliers proved to be more effective in the execution of the process-work and the manufacture of small standard items. The amount of deliveries increased and became more urgent than ever. Therefore, nowadays, the floor at the GI area is covered by parcels waiting to be booked in, and then collected by the material controller to go to the production or assembly lines.

#### Research methodology

For the case study, the data on the warehousing operations were collected through interviews with the key personnel of Lucas Heavy Electricals. Based on the literature, a conceptual model for improving the effectiveness of warehousing operations was developed and reported in the previous section. A case study research methodology was used to study the application of the model. The main objective of the case study is to test our conceptual model for warehousing operations in a section, i.e. the GI section of the company. The data were collected through interviews and from company records. The present warehousing operations system of the company includes many non-value-adding activities. From the case experiences, a new warehousing operations system for the GI section of the company was proposed.

#### Goods inwards operating system

The function of operating systems is to use and convert physical resources into outputs. Basically, there are three categories of physical resources:

- 1 materials;
- 2 machines; and
- 3 labour.

Materials are the physical items consumed and converted by the process. Machines are the physical items used by the system. Labour provides and contributes to the operations of the system. Functionally, there are four categories of operating systems,

such as manufacture, transport, supply, and service.

The principal characteristic of manufacture is that something is physically created. Transport moves things from place. Supply is primarily a function of change in possession of a utility or a resource. The treatment or accommodation of something or someone is provided through the function of service. These four principal functions can together describe every operating system and their sub-systems. Any complex organization can be described using one or all of these functions. Furthermore, consideration of parts or a sub-system of the whole will allow a more accurate description (Wild, 1995).

The warehouse and, therefore, GI, can be described as a supply-operating system. The goods come in from supplies and remain unchanged. The core function of GI is to update the inventory on the information system and to make each component available for collection to the next stage. The components are taken out of their parcel and unloaded into a container designed for their use on the production lines, and the computer system (database) is updated regarding this goods inwards".

#### Customer

The aim of the operation is primarily to provide the modules reliably with the goods from external supply. The basis is to maintain the schedules so that Lucas customers can receive their deliveries on time. One major problem is that, for example, a single missing washer can delay a whole assembly line, and alarmingly reduce its output. This is due to lack of organization or mismanagement of time. Time is a resource which, whether used or lost, is continually passing. Time can be converted into cost in terms of usage of resources in a certain duration, or in terms of costs incurred while not running, hence being one useless overhead.

The production and assembly lines cannot work effectively in JIT, having long lead times owing to supply unreliability. Parts from truck to module may wait for as long as two to five days, or only 15 minutes if they are needed very urgently. Some suppliers are called "approved", others are called "designated". Goods from designated suppliers go to inspection at the vendor quality section before being made available to the module, as sometimes even the suppliers are unsure of what they have sent out; this is a basic requirement of the ISO 9000 standards. Both the approved and designated supplier parts must wait one or two days for the data to be securely entered.

Once ready, the trays go into the storage racks, where they wait to be collected by the

modules. Sometimes, although the parcel is on the premises, it is possible that it has not been booked in, but the information still has to be updated. Consequently, because of a delay on one parcel, a whole module may have to stop, and so it becomes a priority. Therefore, some experience of the stores is helpful in recognizing in advance when such situations might occur.

**Information**

The advice notes are checked and stamped as each parcel is opened. They are grouped and sent to the GI office, where the GI notes are raised. Primarily, the GI notes are useful to the purchasing department. They allow the stock on hand to be kept up to date, so that the inventory control is more accurate and efficient. A green GI note tells the material controllers in the modules where to find the goods they are waiting for, as shown in Figure 3. If, during book-in, the material and the information were to be processed in one sequence of actions, then this new sequence would group the work area and the GI office. The parts wait on the trolley or in a corner until the GI notes are placed into the correct container. This is because the information flow is separated from its real path. By bringing it closer to the unpacking operation, the information will follow, and this would suppress two buffers, since the information mainly concerns the material itself.

The storekeeper raises a GI note, which holds the name (designation), the quantity in the lot, supplier information and the destination. COPICS manages the inventory, and includes an MRP software. The accounts department uses the information from the GI note. When an invoice comes from the supplier, the accountant matches it with the GI note on the screen before paying for the goods, and then the money is sent by

the due date. If, for some reason, the invoice does not match with the information on the screen, the advice note, transported with the goods, is taken out of a fleet as an additional checking process. The quality of available information is crucial in defining the accuracy of long-term forecasts. In this instance, IT is invaluable. It can handle, store and manage an amount of information that would confuse any store manager. What is more value adding, to read the information in an understandable way, or to handle it? IT provides access to more knowledge, more measures and statistics. This also results in a tremendous saving on research, time and money.

**Analysis of activities in the present warehousing operations**

GI operations can be grouped into four main actions:

- 1 the storekeeper receives the parcel in the work area;
- 2 the data are entered on the screen in the GI office;
- 3 dangerous supply is inspected at vendor quality; and
- 4 the parts are kept in the storage area until they are required in the modules.

The GI procedures are detailed in Table I.

**Present system of warehousing operations**

The principal function of GI is to book in the components from external suppliers. The storekeeper prepares them for the module and also updates the information system (COPICS) accordingly. The data are then available to the rest of the factory. Owing to shared printing facilities, the components are handled in a work area, whereas information is treated elsewhere, in the GI office. Long walks are necessary to reach the storage area or the office; subsequently the

**Figure 3**  
 Goods inwards information flow

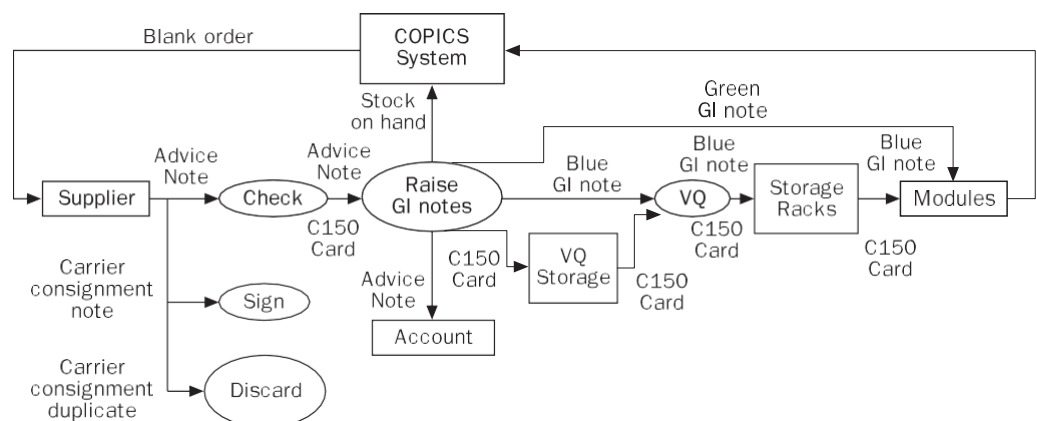

A. Gunasekaran, H.B. Marri and F. Menci  
*Improving the effectiveness of warehousing operations: a case study*

Industrial Management & Data Systems  
99/8 [1999] 328-339

jobs are carried out in batches. Furthermore, the actual waste from the printer is the first two pages and the first two copies of each printed batch. Each form is worth four pence. The actual procedure comprises short sequences of operations, with a buffer in between. The deliveries occur quite irregularly; hence the through-put time from Gate four to the module is difficult to predict. All idle periods, considered as non-value-adding activities, expand this duration. This randomness generates queuing times, between each sequence of up to half a day.

### *Paper work*

The blue GI note exists to travel with the goods. No job must ever be without identification. Each incoming parcel has an attached advice note. One advice note can have many lines - each line calls a job and therefore one GI note. When the parts go into the trays, a C150 card is added, and the advice notes go to the office. The separation of the advice note from the good implies a means of identification of the lot. The GI process note (C150) holds the main information, and remains with the goods, the blue GI note is also added to the tray, the green GI note tells the material controller about the good's availability. The C150 cards hold the same data as the GI note and the advice note. The GI note may be raised in the same place as the C150 card.

It is possible that another procedure may result in the same output. When the advice note is taken out of the parcels, the storekeeper raises the GI notes for each job so that the container and the goods are identified as early as possible. To achieve this, a screen and a printer should be located next to the unpacking area; thus, the information and the material are processed in the same sequence. Such a change may require the form used for the GI note to be modified. The computer can be used as a tool for work enhancement. Through an internal e-mail system, a list of the goods ready in the store and their location will make the green GI note redundant.

### *Queries*

Errors on the paper work (advice notes) or on the screen (order) constitute queries. This is a problem external to GI; nevertheless, it hinders the whole operation. Generally, a mistake in the acquisition of the order on the computer, or a misprint on the paper, can mean the storekeeper trying to resolve the problem for up to half an hour. A double check on the information sent out of the department, allowing the storekeeper to do some corrections, would significantly reduce the time spent on queries.

There are many hindrances in the present GI system of the warehousing operations which cause delay and, hence, increase the number of non-value-adding activities. The

**Table I**  
Activities in the current warehousing operations

Activity no.	Activity type	Description	Activity no.	Activity type	Description
1	Move	Goods arrive from supplier	23	Decision	Does all information match?
2	Operation	Carrier consignment note signed	24	Operation	Query
3	Operation	Duplicate copy	25	Operation	Print out GI notes
4	Waiting	Parcel queue before unpacking	26	Waiting	Batch to be completed
5	Move	Move parcel to work area	27	Waiting	Advice notes are kept five days in the office
6	Operation	Unpack	28	Move	Accounting collect advice note
7	Operation	Find advice note	29	Operation	Record location on GI note
8	Operation	Check advice note	30	Operation	Green GI note to procurement
9	Decision	Is quantity roughly correct?	31	Move	Blue GI notes go with goods
10	Operation	Check on scale	32	Decision	Is inspection required?
11	Operation	Stamp advice note	33	Move	Put trays into VQ storage
12	Operation	Record location on advice note	34	Operation	Write new location on GI notes
13	Move	Empty trays come back from module	35	Move	Blue GI notes into VQ file
14	Operation	Put components in tray	36	Waiting	Wait for inspection
15	Operation	Write C150	37	Operation	Inspection
16	Operation	Put C150 in tray	38	Move	Blue GI notes with goods
17	Waiting	Fill the trolley	39	Decision	Pass?
18	Move	Move trolley to waiting area	40	Operation	Non-conformance procedure
19	Waiting	Trolley wait for GI note	41	Move	Trays go into storage racks
20	Move	Advice note taken to office	42	Waiting	Wait for module collection
21	Waiting	Waiting for book-in	43	Move	Goods are taken to module + blue GI note + C150
22	Operation	Raise GI note			

---

A. Gunasekaran, H.B. Marri  
and F. Menci  
*Improving the effectiveness of  
warehousing operations: a  
case study*

---

Industrial Management &  
Data Systems  
99/8 [1999] 328-339

---

factors which affect the GI system of warehousing operations are as follows:

- long lead time because of delays which arise from many hand-offs;
- poor warehouse layout;
- limited printing facilities;
- poor format of the information output that leads to wastage of papers on the printer;
- there are many activities in the GI system which increase the number of buffers and hence the inventory build-up;
- irregular deliveries owing to poor communication in the GI system;
- increase in the queuing time of goods because of the above reasons;
- high level errors in the forecasting of demand; and
- unnecessary queries such as errors on the advice notes, on the order and a misprint on the paper that can increase the congestion in the warehousing operations.

#### **Proposed system of warehousing operations**

GI operation improvements lie in the way information is handled. The areas which appear to have the highest potential for improvement are the electrical supply area and in-line goods. The changes would not modify the book-in procedure in so far as the staff may only require a broader understanding of why they will have to handle parts as much as their respective information. Basically, the unpacking and transport of the physical items are considered to be the core activities of GI, whereas the other activities could be seen as a polluting, non-value-adding activity. Information is actually processed centrally in the GI office. The removal of the GI office will thus affect every sub-area in the GI department. Each sub-area may require a specific analysis to define accurately how and where to handle the parts with their information. Of the two stations, one can be made available on a part-time basis to raise the GI notes for the other sub-areas until the change takes place in the whole department. The proposed processes for warehousing operations are detailed in Table II.

#### ***Implications of the proposed warehouse operations system***

The implementation of a new layout involves change in the whole structure of the GI operating system. Therefore, it needs to follow certain steps which include:

- 1 change the layout for the electrical supply;
- 2 develop suitable performance measures;
- 3 review the new layout within the scope of the department;

- 4 employ large containers, recycling of raw materials, certified suppliers with small and medium-size deliveries; and
- 5 continuous improvements.

#### ***Poste de manoeuvre***

Once the parts are in a tray with their correct GI note, they can be placed in the storage racks. The distance between this area and the working area justifies the use of the trolley to batch this operation. Primarily, the actual batch size is defined by the capacity of the trolley. It appears to be satisfactory. A further study may be useful to determine the optimal size of the trolley. Nevertheless, the behaviour of this new system must be measured, so that every parameter is under control. A gravity conveyor placed at the centre of the room will handle the incoming parcels. Two work stations at each side will be equipped with a terminal to raise the GI notes. A printer can be shared among the two operators. The printer must be able to produce each form economically. As the activities take place at the centre of the room, the storage racks can be arranged around the room. They should be coded according to the destination of the goods stored. Then buffer stores may be set aside for queries, where parcels can wait while a query is solved without delaying the subsequent jobs.

#### **Comparison of the present and proposed systems of warehousing operations**

Comparison of the present and proposed systems of warehousing operations was carried out to determine the number of value-adding and non-value-adding activities in the GI operating system. In the proposed system of warehousing operations, the total number of activities is reduced from 43 to 30 activities. Also, the number of value-adding activities has increased by 7.44 per cent and at the same time the number of non-value-adding activities has decreased by the same ratio in the proposed system of the GI operations. JIT and TQM strategies/methods help to improve the information flow and hence the flow of materials through the supply chain, which leads to a reduction in the number of non-value-adding activities and hence the lead time. For example, JIT requires having only the necessary stock to meet demand and, therefore, it reduces the inventory level and associated costs which in turn improves the working environment. Implementation of JIT even simplifies the information system and its applications, leading to improved communications between suppliers and customers. TQM leads to improved understanding of the warehousing operations and their business objectives by the employees. This would lead to

A. Gunasekaran, H.B. Marri and F. Menci  
*Improving the effectiveness of warehousing operations: a case study*

Industrial Management & Data Systems  
99/8 [1999] 328-339

teamwork and co-operative supported work. IT facilitates better communication with suppliers leading to improved delivery performance and reduction in inventory costs. All of these have aimed to reduce the number of non-value-adding activities in the GI system. The percentage of activities with present and proposed systems of GI warehousing operations is shown in Table III.

### Summary of findings and recommendations

Presented here are some of the findings and recommendations on the reduction of through-put time in warehousing operations:

- The processing of information plays a vital role in warehousing activities. Each individual batch has its own specific details, such as its origin, supplier, identification and its final destination. It is, therefore, clear that an efficient and reliable data handling system is needed to store accurately the extensive amount of information on goods and their movements.
- There are obvious benefits that warehousing can bring. Provided that the warehouse is run competently (that is, the stock for each item is at the correct level, the warehouse capacity fits its purpose and the goods are appropriately stored), the general level of organization in terms of distribution will ensure effectiveness, promote customer satisfaction and could potentially facilitate profit-building opportunities.
- There are, however, some sacrifices to be made when using JIT. In Japan, for example, companies have close control

Table III

Percentage of activities before and after the proposed processes

Nature of activities in GI system	Present system of GI	Proposed system of GI
Value-adding	32.56	40
Non-value-adding	67.44	60

over their suppliers, and demand more frequent deliveries. This in turn requires a greater level of transportation and therefore creates more traffic, which is already a problem in Japanese cities. A further problem with JIT may arise when an item inventory is cut to zero, as a company has no safety stock. This will have serious implications for the company if there is suddenly a surge in demand. To prevent such a situation, the inventory level of an item (particularly low value and low volume items) would be pegged at a point between JIT delivery and the holding of stock.

- The principal concept behind JIT philosophy involves solving productivity problems by improving manufacturing efficiency. It can be argued that this, together with other important elements of JIT, form part of a TQM attitude which, in its widest sense, aims to improve a company's general effectiveness by working to advance the social aspect of management. More precisely, this would require the active participation of all management members, working towards customer satisfaction and benefits for both the organization and society in general.

Table II

Proposed activities for warehousing operations

Activity No.	Activity type	Description	Activity No.	Activity type	Description
1	Move	Goods arrive from supplier	16	Waiting	Advice notes are kept five days in the office
2	Operation	Carrier consignment note signed	17	Move	Accounting collect advice note
3	Operation	Duplicate copy	18	Operation	Put components in tray
4	Waiting	Parcel queue before unpacking	19	Operation	Print out GI notes
5	Move	Move parcel to work area	20	Move	GI notes go with goods
6	Operation	Unpack	21	Waiting	Wait for batch to complete
7	Operation	Find advice note	22	Decision	Is inspection required?
8	Operation	Check advice note	23	Move	Put trays into VQ storage
9	Decision	Is quantity roughly correct?	24	Waiting	Wait for inspection
10	Operation	Check on scale	25	Operation	Inspection
11	Operation	Stamp advice note	26	Decision	Pass?
12	Operation	Raise GI note	27	Operation	Non-conformance procedure
13	Decision	Does all information match?	28	Move	Trays go into blue storage racks
14	Operation	Query	29	Waiting	Wait for module collection
15	Move	Empty trays come back from module and write C150	30	Move	Goods are taken to module

---

A. Gunasekaran, H.B. Marri  
and F. Menci  
*Improving the effectiveness of  
warehousing operations: a  
case study*

---

Industrial Management &  
Data Systems  
99/8 [1999] 328-339

---

- After the analysis of the GI procedure, it appears that information handling, supposedly a core activity, is separated from the physical flow of material; this means that one activity waits for the other, and thereby buffers and delays are generated. Hence to reduce lead time and thus through-put time, a greater emphasis should be placed on the information flow. The GI operating system requires some structural changes, such as the introduction of an individual screen and printer for each operator. The program described in the *Poste de manoeuvre*" section aims to provide guidelines for the implementation of an efficient data collection system for the goods from external supply.
- The level of technology has an effect which is independent of the efficiency intrinsic to the operating system. Bar-coding and EDI would prove useful, but would require some supporting structures before being implemented. The state of the implementation system in the warehouse does not allow such improvements. However, it is important to provide operational efficiency before moving towards advanced technology. EDI may be the next logical step for future improvement.
- There is a lack of software packages to cover the application areas in manufacturing or distribution companies. Enterprise resource planning (ERP) software packages can be expanded to handle multi-stockroom and warehouse operations, multi-company operations, and multi-currency applications. Prospective ERP system buyers need to be forewarned that the performance quality and cost of various packages with performance claim in different areas vary greatly (Prather, 1997).

---

## Conclusions

An attempt has been made in this paper to study the effectiveness of warehousing operations, its requirements and the benefits it may bring. A conceptual model has been developed to improve the effectiveness of warehousing operations. Also, a case study has been conducted for goods-inwards operations in one of the sections of the warehousing operations in Lucas at Acton, UK. Finally, the summary of findings and recommendations from the case study are presented in this paper. This paper stresses the importance of efficient warehouse management, since the activities performed

in a warehouse environment have a direct influence on the overall effectiveness of a company and its customer service levels, and are, therefore, a factor affecting profit. It is essential to ensure that there is a sound warehousing methodology in operation, whereby the distribution of goods from the production line to the customer takes place economically and punctually, using a shortest-path philosophy, and avoiding unnecessary waiting time. In addition to this, the following may improve the warehousing efficiency:

- moving to make-to-order system;
- pull production system;
- electronic data interchange;
- eliminating incoming goods inspection to a minimum level;
- improved accuracy of the forecasting; and
- minimum personnel in GI system.

---

## References

- Ang, B. and Andren, E.A. (1995), Warehouse overhaul eliminates bottlenecks", *ID Systems*, Vol. 15 No. 3.
- Burton, J.A. (1981), *Effective Warehousing*, 3rd ed., Macdonald & Evans Ltd, Plymouth.
- Cali, J.F. (1993), *TQM for Purchasing Management*, McGraw-Hill, New York, NY.
- Chaudhuri, S. and Dayal, U. (1997), Data warehousing and OLAP for decision support", *SIGMOD Record*, (ACM Special Interest Group on Management of Data), Vol. 26 No. 2, pp. 507-8.
- Chorafas, D.N. (1974), *Warehouse Planning, Organizing and Controlling the Storage and Distribution of Goods*, Macmillan Press Ltd, London.
- Cormier, G. and Kersey, D.F. (1995), Conceptual design of a warehouse for just-in-time operations in a bakery", *Computers and Industrial Engineering*, Vol. 29 Nos 1-4, pp. 361-5.
- Daniels, R.L., Flummel, J.L. and Schantz, R. (1998), Model for warehouse order picking", *European Journal of Operational Research*, Vol. 105 No. 1, pp. 1-17.
- Dilger, K.A. (1998), We're all connected", *Manufacturing Systems*, Vol. 16 No. 5, pp. 50-6.
- DTI (1995), *Logistics and Supply Chain Management, Managing in the '90s*, HMSO, London.
- Fuller, N.W. (1995), Just-in-time purchasing and supply: a review of the literature", *International Journal of Operations & Production Management*, Vol. 15 No. 9, pp. 220-36.
- Love, P.E.D., Gunasekaran, A. and Li, H. (1998), Improving the competitiveness of manufacturing companies by continuous incremental change", *The TQM Magazine*, Vol. 10 No. 3, pp. 177-85.

---

A. Gunasekaran, H.B. Marri and F. Menci  
*Improving the effectiveness of warehousing operations: a case study*

---

Industrial Management & Data Systems  
99/8 [1999] 328-339

---

Lysons, K. (1996), *Purchasing*, 4th ed., M&E Pitman Publishing, London.

Nixon, K. (1994), How to choose the best warehouse control system to meet your needs", *Material Handling Engineering*, Vol. 49 No. 2.

Prather, K. (1997), Buyer beware: dos and don'ts of software selection", *Annual International Conference Proceedings - American Production and Inventory Control Society*, pp. 190-5.

Suskind, P. (1995), Warehouse operations: don't leave well enough alone", *IIE Solutions*, Vol. 27 No. 8.

Tompkins, J. (1996), Measuring warehouse performance: how are you doing?", *Annual International Conference Proceedings - American Production and Inventory Control Society*, pp. 218-23.

Trunk, C. (1994a), Exploring options with warehousing software", *Material Handling Engineering*, Vol. 49 No. 2.

Trunk, C. (1994b), Using barcodes for warehouse control", *Material Handling Engineering*, Vol. 49 No. 10, pp. 48-52.

Wild, R. (1995), *Production and Operation Management*, 5th ed., Cassell, London.

## Note from the publisher New for 2000

Next year, all subscribers will be able to take advantage of the following benefits provided for the readers of Industrial Management & Data Systems:

### Extra issue

From 2000, IMDS will consist of nine issues per volume in place of the previous eight issues – extra quantity but with the same high quality.

### Follow the reference trail

- References cited in any paper can be followed up via our new Reference Linking service. Access the journal via the Internet, click on the reference and read an abstract of the actual paper referred to. Where possible, we will also be providing the link to the full text of the paper.
- Research demands that you know and explain the provenance of ideas. Reference Linking allows you to trace back through the development of a topic while sitting at your own PC. What could be easier?

### Review the world's information management and technology literature

- A subscriber can obtain access on the Internet to Information Management and Technology Abstracts via the Anbar Electronic Intelligence database. Specialist abstractors classify and abstract the content of many of the world's key publications in the field. These abstracts will be open to you to search and scan. Full text is available at a reasonable cost and access is obtained through the journal's contents pages on the Website.
- Keep up with what is being published in journals such as *Datamation*, *PC Magazine*, *Decision Support Systems*, *Journal of Database Management*, and *European Journal of Information Systems*.

**This article has been cited by:**

1. Nur Hazwani Karim, Noorul Shaiful Fitri Abdul Rahman, Syed Faizal Shah Syed Johari Shah. 2018. Empirical Evidence on Failure Factors of Warehouse Productivity in Malaysian Logistic Service Sector. *The Asian Journal of Shipping and Logistics* **34**:2, 151-160. [[Crossref](#)]
2. CalzavaraMartina, Martina Calzavara, PersonaAlessandro, Alessandro Persona, SgarbossaFabio, Fabio Sgarbossa, VisentinValentina, Valentina Visentin. 2018. A device to monitor fatigue level in order-picking. *Industrial Management & Data Systems* **118**:4, 714-727. [[Abstract](#)] [[Full Text](#)] [[PDF](#)]
3. Željko Stević, Enis Mulalić, Zdravko Božičković, Slavko Vesković, Irena Đalić. 2018. Economic analysis of the project of warehouse centralization in the paper production company. *Serbian Journal of Management* **13**:1, 47-62. [[Crossref](#)]
4. Francielly Hedler Staudt, Gülgün Alpan, Maria Di Mascolo, Carlos M. Taboada Rodriguez. 2015. Warehouse performance measurement: a literature review. *International Journal of Production Research* **53**:18, 5524-5544. [[Crossref](#)]
5. Agata Banaszewska, Frans Cruijssen, Wout Dullaert, Johanna C. Gerdessen. 2012. A framework for measuring efficiency levels—The case of express depots. *International Journal of Production Economics* **139**:2, 484-495. [[Crossref](#)]
6. Anna Corinna Cagliano, Alberto DeMarco, Carlo Rafele, Sergio Volpe. 2011. Using system dynamics in warehouse management: a fast-fashion case study. *Journal of Manufacturing Technology Management* **22**:2, 171-188. [[Abstract](#)] [[Full Text](#)] [[PDF](#)]
7. Florence Yean Yng Ling, Francis Tekyi Edum-Fotwe, Moxham Thor Huat Ng. 2008. Designing facilities management needs into warehouse projects. *Facilities* **26**:11/12, 470-483. [[Abstract](#)] [[Full Text](#)] [[PDF](#)]
8. Harry K.H. Chow, K.L. Choy, W.B. Lee. 2007. Knowledge management approach in build-to-order supply chains. *Industrial Management & Data Systems* **107**:6, 882-919. [[Abstract](#)] [[Full Text](#)] [[PDF](#)]
9. S. Y. Chin, H.L.J. Pontes, A.J.V. Porto. Retrieving Process Analysis in a Parts Distribution Center: A Case Study of Manual Trolley Fleet Substitution 2506-2512. [[Crossref](#)]



[contact@solti-software.com](mailto:contact@solti-software.com)

<https://smart-inventory-manager.com>